

TREADBRITE TEXTURE NOT SHOWN IN TOP VIEW

COMP	HEIGHT	WIDTH	DEPTH	OUTLET
D/W INNER	28.00	36.00	12	7.00
D/W OUTER	68.87	36.00	14	18.81
D/W	38.87	63.38	14	18.84
D/W INNER	28.00	58.19	12	10.83
D/W OUTER	68.87	58.19	14	32.65
P/W INNER	10.72	14	12	7.46
P/W OUTER	68.87	36.00	14	18.81
P/W	38.87	40.38	14	12.07
P/W INNER	28.00	58.19	12	10.83
P/W OUTER	68.87	58.19	14	30.45
C/W	10.72	14	14	12.46
C/W	15	68	109	64.34
R-1	44.00	44.00	30	33.61

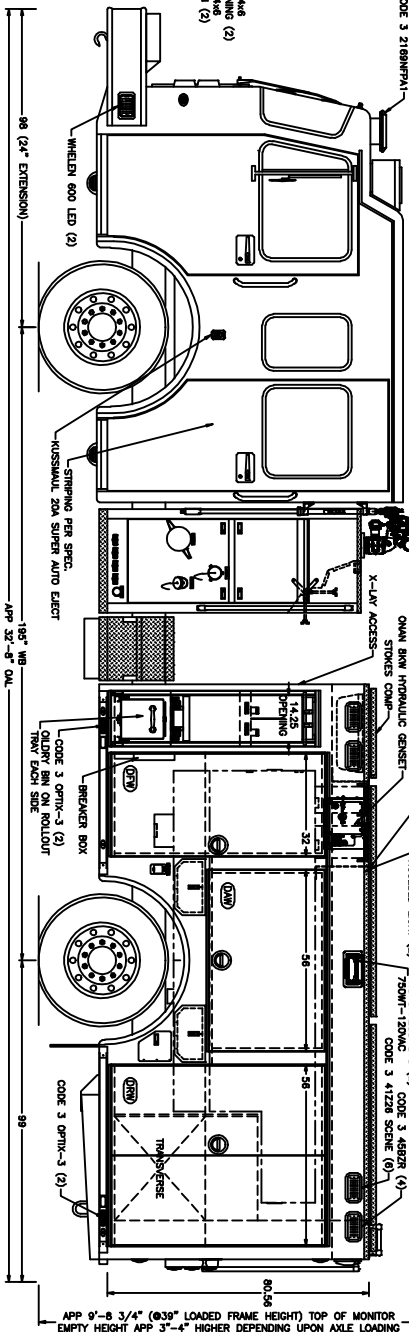
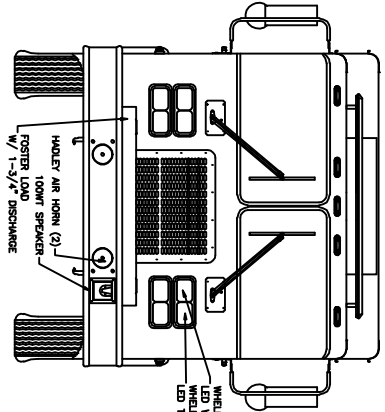
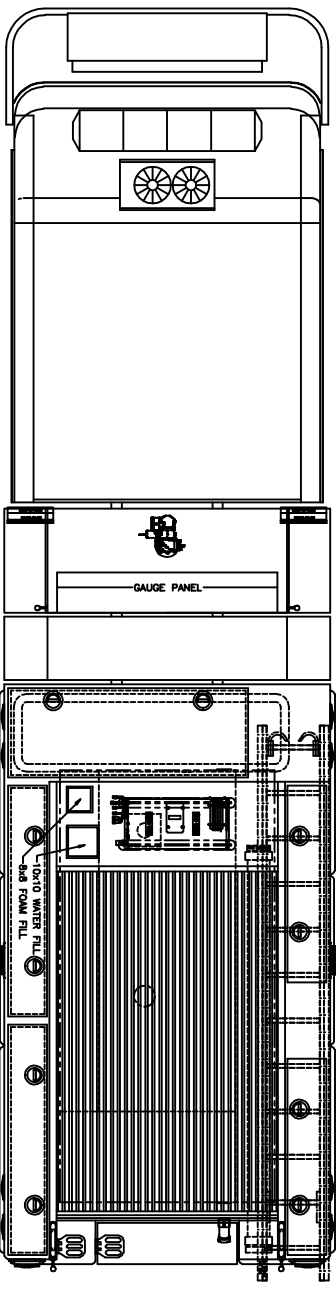

NOTE:
DIMENSIONS SHOWN ARE APPROXIMATE AND ARE SUBJECT TO MINOR CHANGE AS MAY BE FOUND NECESSARY DURING CONSTRUCTION. MINOR DETAILS MAY NOT BE SHOWN. IF DISCREPANCIES EXIST BETWEEN THIS DRAWING AND THE WRITTEN SPECIFICATIONS PROVIDED BY TOYNE, THE WRITTEN SPECIFICATIONS SHALL PREVAIL.

TOYNE FIRE APPARATUS	
BREDA, IOWA 51436	
9104 DEMO	CUSTOM PUMPER
CHASSIS: SPARTAN BIG EAST	SCALE: 1/64 [LD] BY: SCHMIDT
WB-CA: 195"-141"-47"	DATE: 28 NOV 2007
BODY: ALUMINUM	DISC: 9104-A
PUMP: HALE DSD 1500	
TANK: 1000/25 UPF POLY	
GENSET: 8KW ONAN HYDRAULIC	
3/14/08-AS BUILT-BLK	